

Company Introduction



June.2007

www.carr.com.cn / www.carr.net.cn





Brief Introduction about Kairui

- The company combines products research, design, manufacture, marketing and service together for providing the customers with perfect transportation solution.
- Has been manufactured more than 200 units of equipments with many products series such as slag pot carrier, pallet transporter, ladle carrier, etc.
- The core product slag pot carriers are ranging from 35t-125t, which have covered the domestic market and have been sold to Malaysia and Korea.



The Development of Company

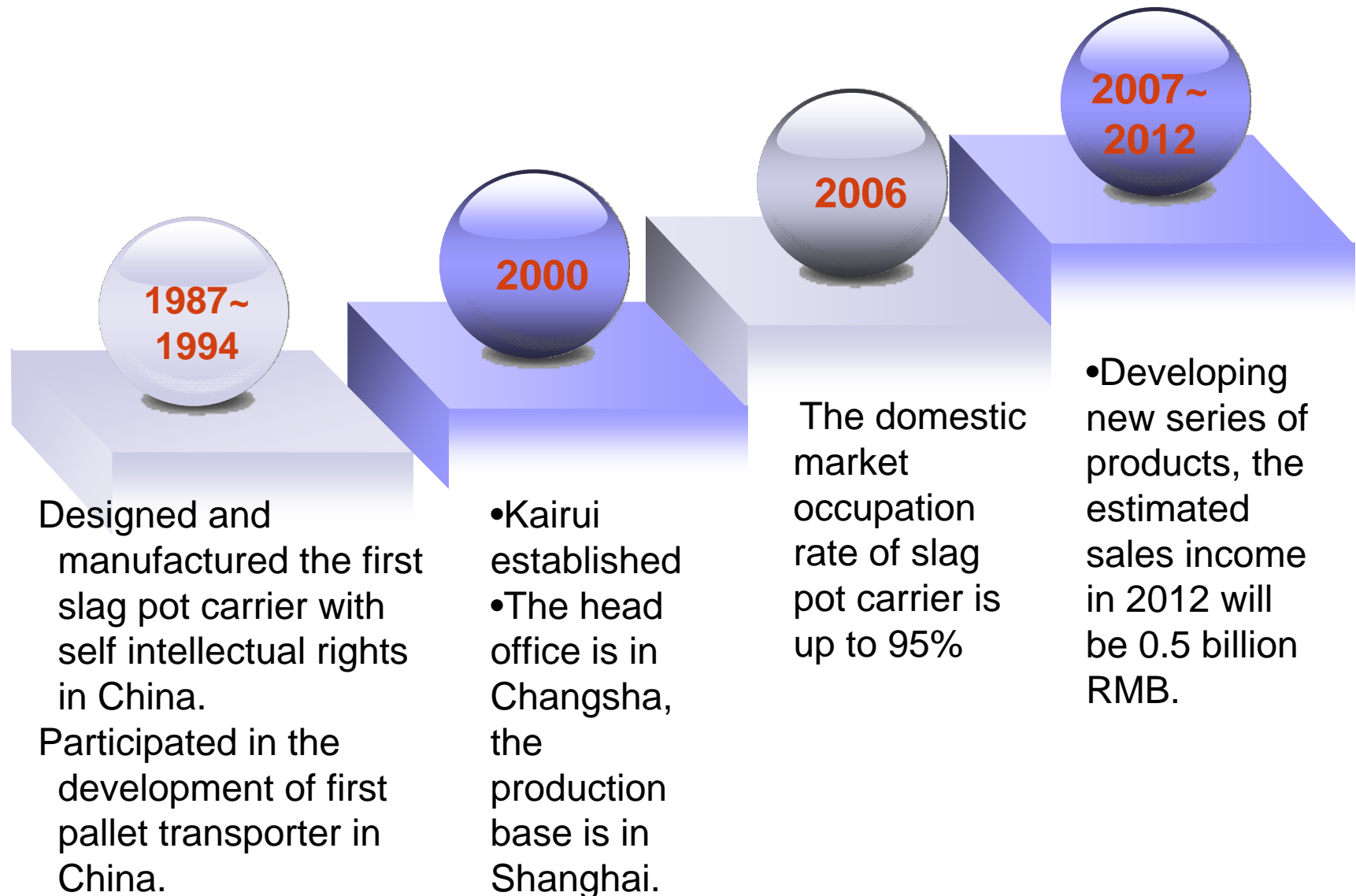

Production Capability

- Head headquarters is in Changsha,
- Production base is in Shanghai with production capacity up to 0.3 billion RMB.



Technical Cooperation

- Cooperating with named universities and overseas companies
- Establishing expert council for guiding the strategic development of company.



Professor
Zhongjue
Academician of
CAE



Liuliangcheng
Senior
engineer of
Liugong Group



Qualification & Patent

- ISO 9001
- 6 practical technology patents
- License for manufacturing special equipments issued by state authority.
- Involved in “Development Program of Chinese Metallurgical Industry”.



Designing Software

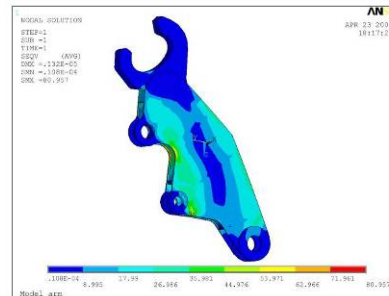
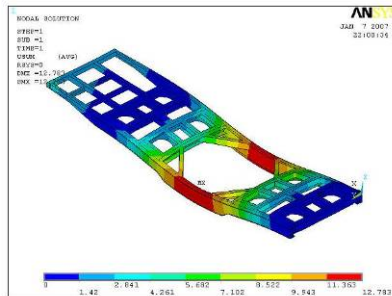

The FEA stress cloud chart

3D model of hydraulic suspension

3D design, FEA are introduced as computer assistant designing platform, by using“ Virtual simulation” can realize “ overall visualization” analysis.



Products Series

Slag pot carrier:

- Tractor type

- Articulated type

- U - Frame

Pallet transporter for steel plant, shipyard and port

Others:

- Skip handler,

- Remote control crawl loader

- Ladle carrier

- Tractor

BGC Articulated Type



BGC60



BGC60



BGC50



BGC45

BGC Tractor Type



•BGC35



•BGC40

•Tractor type (payload:
30t~60t)



BGC U-Frame slag pot carrier

U-Frame Design Features:

1. Low Frame Profile
2. Dual Facing Operator Station
3. Cam-Lift Mechanism
4. Articulated Steering
5. High Hydraulic Capacity
6. Quick Drop: Allows sticker material to be vibrated and loosened from pots.

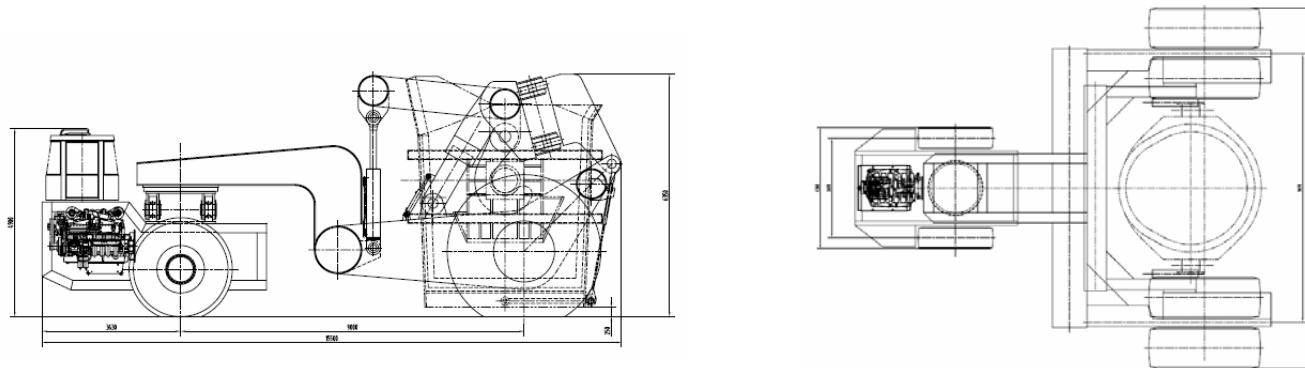

PT Pallet Transporter



Objective: Scrap, liquid iron and steel, hot billet or finished/ semi-manufactured goods.

Payload 90t-200t



PT Pallet Transporter

Module transportaion

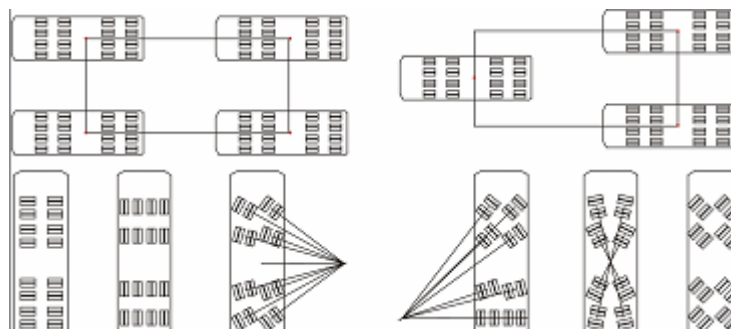

For carrying block and prefabricated sections in Shipyard



TSB Ladle carrier

Work for blaster furnace and converter, heavy payload ranging from 40t-145t.



Tractor Type



Articulated Type

SKC Skip Handler

Suitable for transport oxidized iron, scrap, and industrial waste. Various imported and homemade chassis are optional for customer.



Remote control crawl loader

With remote control function, provide protection for hydraulic parts, adopt solid tyre and other facilities to meet the working environment of steel plant, suitable for non-stop slag cleaning under converter.



LST Tractor

As a accompanying Vehicle for slag pot carrier, can be suitable for port transportation. Articulated steering, hydromechanics transmission.



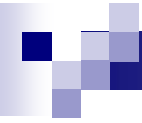

Service Network



Main Customers



SINOSTEEL

中国中钢集团公司
SINOSTEEL CORPORATION



BAOSTEEL



鞍山钢铁集团公司
Anshan Iron and Steel Group Corporation



沙钢集团
SHAGANG GROUP



武汉钢铁(集团)公司
WUHAN IRON AND STEEL (GROUP) CO., LTD.



中国冶金科工集团公司
CHINA METALLURGICAL GROUP CORP.



天津钢铁



興澄特钢
XINGCHENG STEEL



JISCO



ZENITH
中天钢铁



南京钢铁集团有限公司
NANJING IRON&STEEL GROUP CO., LTD.



华鑫集团
VALIN

MITTAL



MEGASTEEL
SDN BHD



ECOMAISTER

SeAH



BHUSHAN

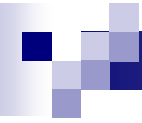

Cooperated Suppliers

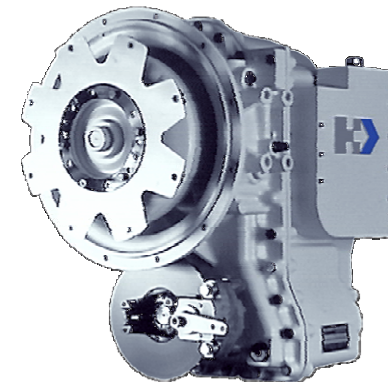
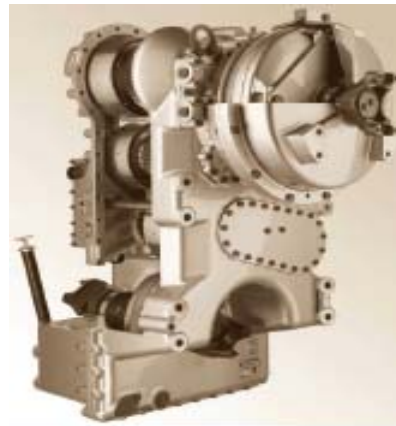
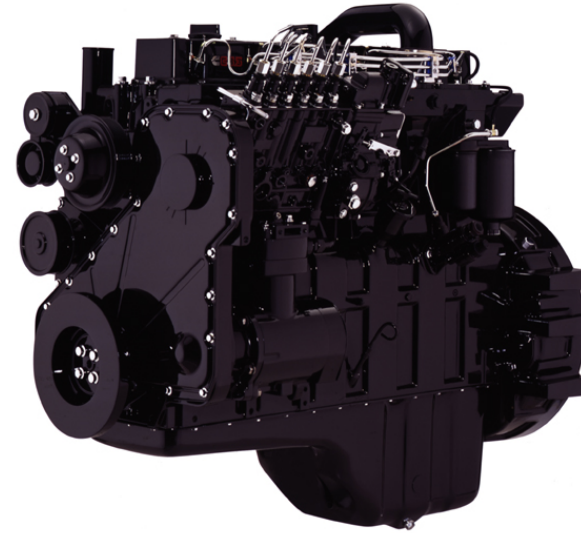

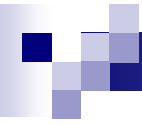

Cooperated Suppliers



www.carr.com.cn / www.carr.net.cn

For solution of your Transportation

Headquarters:

Add: No.96 Tongzipo Road. Changsha Hunan China. P.C:410013

Tel: 86-731-8903715, 8905382 Fax: 86-731-8903855